



Page 728
**Vertical Toggle Clamp
with Adapter**



Page 729
**Horizontal Toggle Clamp
with Adapter**



Page 730
**Adapter with Hole Pattern
Ø 48 / 15 for Toggle Clamp**



Page 730
**Adapter Blank without Hole Pattern
Ø 48 / 15 for Toggle Clamp**



Vertical Toggle Clamp with Adapter

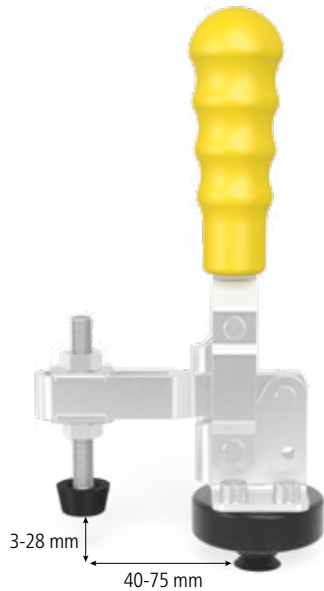

160705

009082

Description:

Vertical Toggle Clamp with Adapter, universally usable with 16 mm bore holes. Maximum functionality is achieved in combination with the Universal Stop (Item No. 160420.N).

The Adapter is replaceable. Further sizes see page 730.

Further Quick-Change Clamps can be found on the Internet at www.siegmund.com

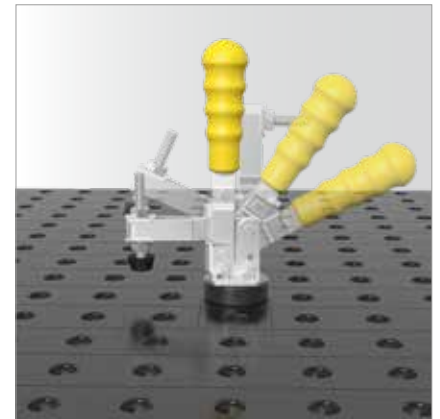
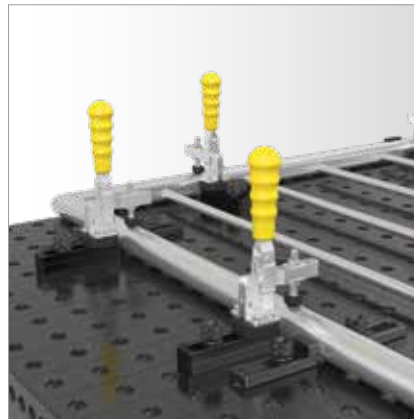

Vertical Toggle Clamp with Adapter

- Adapter 160715

Weight:

0,95 kg

Item No.

2-160705 ●

Vertical Toggle Clamp

0,39 kg

2-009082 ●

● = Item produced for stock; ○ = Item produced on order; Explanations see page 84

Horizontal Toggle Clamp with Adapter

Description:

The Horizontal Toggle Clamp with Adapter is universally usable, with 16 mm bore holes. Highest efficiency is achieved in combination with the Universal Stop (Item No. 160420.N).

The Adapter is replaceable. Further sizes see page 730.

Further Quick-Change Clamps can be found on the Internet at www.siegmund.com

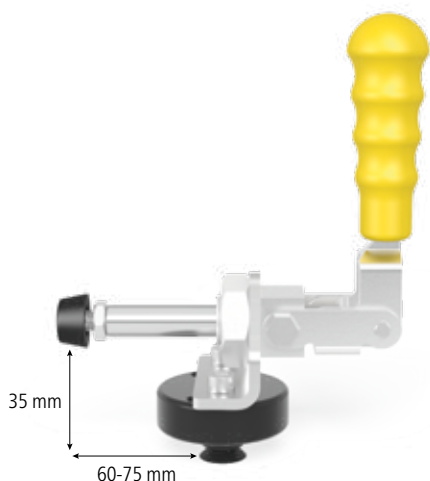

160710



009083

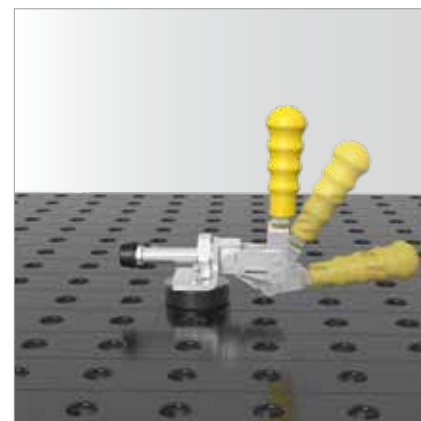

Horizontal Toggle Clamp with Adapter
- Adapter 160715

Weight: **Item No.**

0,91 kg 2-160710 ●

Horizontal Toggle Clamp

0,40 kg 2-009083 ●

● = Item produced for stock; ○ = Item produced on order; Explanations see page 84



Adapter with Hole Pattern / Adapter Blank without Hole Pattern

Description:

Adapter with Hole Pattern, universally usable in all 16 mm bore holes. With the integrated O-ring maximum fitting accuracy is achieved.



160715



160720

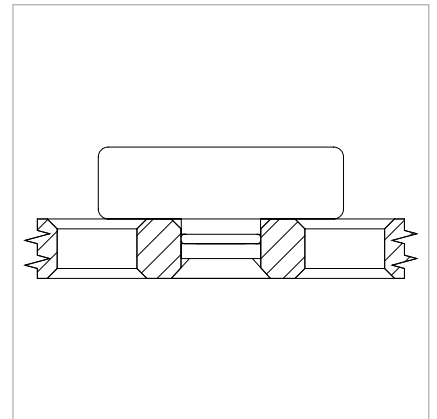
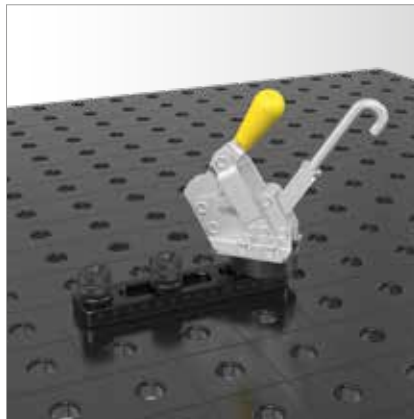

	Height: (c)	Ø: (o)	MS: (d)	Weight:	Item No.
Adapter with Hole Pattern Ø 48 / 15 - for Toggle Clamp - burnished	22 mm	48 mm	15 mm	0,20 kg	2-160715 ●
Adapter Blank without Hole Pattern Ø 48 / 15 - for Toggle Clamp - burnished	22 mm	48 mm	15 mm	0,25 kg	2-160720 ●

MS=Material thickness; ● = Item produced for stock; ○ = Item produced on order; Explanations see page 84

